



Technical brochure

# Differential pressure controls, Type MP54 and MP55



MP 54 and MP 55 oil differential pressure controls are used as safety switches to protect refrigeration compressors against low lubricating oil pressure.

If the oil pressure fails, the control will stop the compressor after a predetermined time period has elapsed.

MP 54 and 55 are used in refrigerating systems using HCFC, HFC.

MP 54 has a fixed differential pressure setting. It also incorporates a thermal time relay with a fixed release time setting.

MP 55 have adjustable differential pressure and are available with thermal time relay.

## Features

- Fixed and adjustable differentials available
- 240 or 120 V AC or DC control voltage
- Simple manual trip, electrical test function eliminates need of tools and test "jumper" wires
- Extremely narrow switch differential accuracy
- Reliable, long life stainless steel bellows
- Sturdy metal cover and universal mounting hole patterns
- Integral 1/2 NPSM swivel cable connector allows direct attachment of 1/2 in. male pipe thread connector
- Standard four-wire hook-up
- Refrigerants HCFC, HFC



**Approvals**

UL listed for USA and Canada, file E31024

**Materials in contact with the medium**

Unit type	Material
MP 54 MP 55	Stainless steel 19/11, no. 1.4306 to EN10088 Deep-drawn steel plate, no. 1.0338 to EN10130 Free cutting steel, no. 1.0718 to EN10277
MP with capillary tube	Copper Cu-DHP, no. CW024A acc. to EN12450

**Technical data**

*Maximum bellows temperature*  
212°F

*Temperature compensation*  
The time relay is temperature-compensated in the range – 40 to 140°F

*Switch differential*  
Maximum 2.8 psi

*Maximum working pressure*  
MWP = 245 psig

*Maximum test pressure*  
p' = 320 psig

*Control voltage*  
240 V or 120 V AC or DC

*Permissible voltage variation*  
-15% to +10%

*Contact load*  
of time relay output contacts M-S  
240 V AC: 2 FLA  
240 V AC\*: 0.2 FLA  
\* Not approved for DC application

*Cable entry*  
Integral 1/2 in. female NPSM swivel cable connector allows direct attachment of 1/2 in. male pipe thread connector.

*Enclosure*  
NEMA 1; IP 20 to IEC 529

Ordering

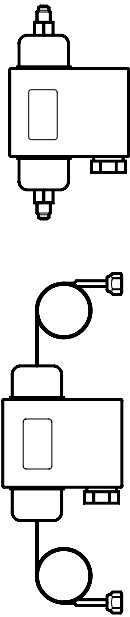

Type	Control differential $\Delta p$ psi	Regulation range LP side in. Hg to psig	Time relay delay time s	Pressure connection			Code no.
				1/4 in. flare	36 in. capillary tube	88 in. capillary tube	
MP 54	fixed 6.0	29 in. to 170	45	+			060B200866 <sup>1)</sup>
MP 54	fixed 6.0	29 in. to 170	45		+		060B205066 <sup>1)</sup>
MP 54	fixed 6.0	29 in. to 170	45			+	060B205866
MP 54	fixed 6.0	29 in. to 170	60		+		060B205966
MP 54	fixed 9.0	29 in. to 170	60	+			060B200166
MP 54	fixed 9.0	29 in. to 170	60		+		060B205166
MP 54	fixed 9.0	29 in. to 170	90	+			060B200266
MP 54	fixed 9.0	29 in. to 170	120	+			060B200366 <sup>2)</sup>
MP 54	fixed 9.0	29 in. to 170	120		+		060B205366 <sup>2)</sup>
MP 55	4.3 to 64	29 in. to 170	45		+		060B205466
MP 55	4.3 to 64	29 in. to 170	60	+			060B201266 <sup>3)</sup>
MP 55	4.3 to 64	29 in. to 170	90	+			060B200666
MP 55	4.3 to 64	29 in. to 170	90		+		060B205666
MP 55	4.3 to 64	29 in. to 170	120	+			060B200766
MP 55	4.3 to 64	29 in. to 170	120		+		060B205766

- <sup>1)</sup> Corresponds to CARRIER/CARLYLE specifications.
  - <sup>2)</sup> Correspond to COPELAND specifications.  
Three-wire hook-up.
  - <sup>3)</sup> With operational light that remains on during normal operation of compressor.
- Note:** When time delay is energized which also means that min. permissible oil pressure (differential  $\Delta p$ ) is reached, light goes out.

Design

1. Connection to pressure side of lubrication system, OIL
2. Connection to suction side of refrigeration plant, LP
3. Setting disc
4. Reset button
5. Test device

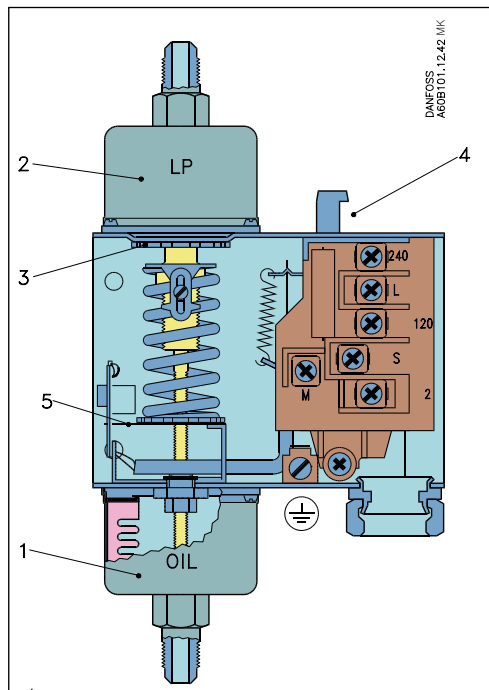

The operation of the pressure control is based only on the differential pressure, i.e. the difference in pressure between the two counteracting bellows, whereas it is independent of the absolute pressure acting on both bellows.

The MP 55 can be set for different differential pressures by the setting disc (3). The set differential pressure can be read from the internal scale.

The MP 54 has a fixed differential and has no pressure setting disc. The factory-set differential pressure is stamped on the front plate of the control.

**Terminology**

**Differential range**

The pressure difference between LP and OIL connections within which the control can be set to operate.

**Contact differential**

The pressure rise above the set differential pressure (scale reading) necessary to cut off current to the time relay.

**Scale reading**

The differential between the oil pump pressure and the pressure in the crankcase that exists at the moment the contact system cuts in current to the time relay on falling oil pressure.

**Release time**

The period for which the differential pressure control allows the compressor to run with too low an oil pressure during start-up and operation.

**Operating range**

The pressure range on the LP connection within which the control can operate.

**Electrical diagram**

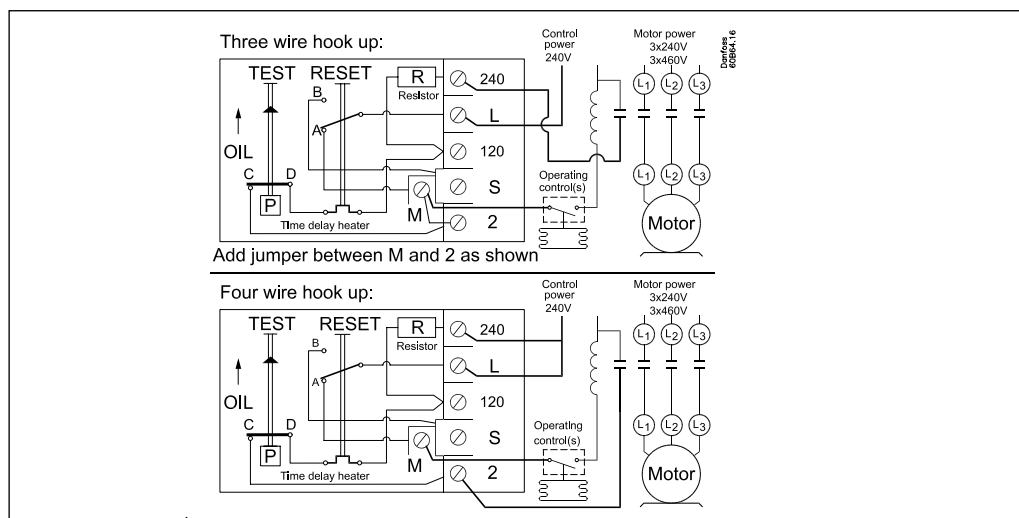

**Dimensions and weights**

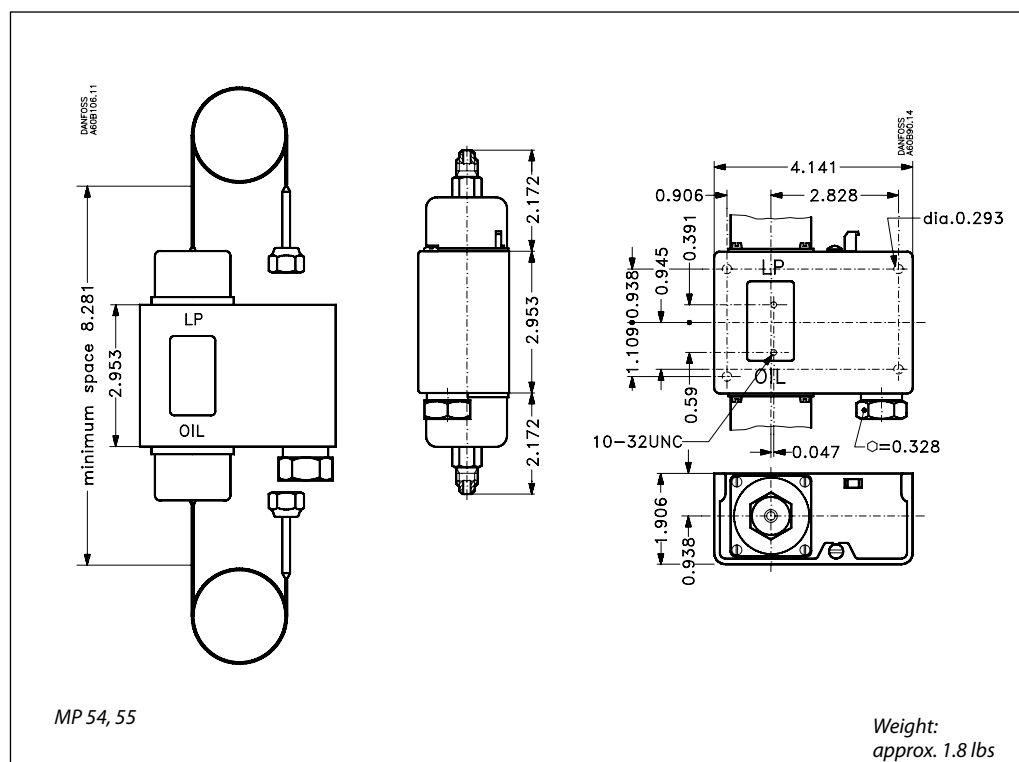

**Function**

If there is no oil pressure on starting, or if the oil pressure falls below the set pressure during operation, the compressor will stop after the release time has elapsed. The electrical circuit is divided into two completely separate circuits, a safety circuit and an operational circuit. The timer in the safety circuit is activated when the effective lubricating oil pressure, the oil differential pressure (the difference between the oil pump pressure and suction pressure), is lower than the set value.

The timer is deactivated when the oil differential pressure is more than the set value plus the contact differential.

The two diagrams below explain the terms “oil differential pressure” and “contact differential”, both have to be considered when using oil differential pressure controls.

The first diagram shows the function of the differential control during start; the second shows the function of the control during operation.

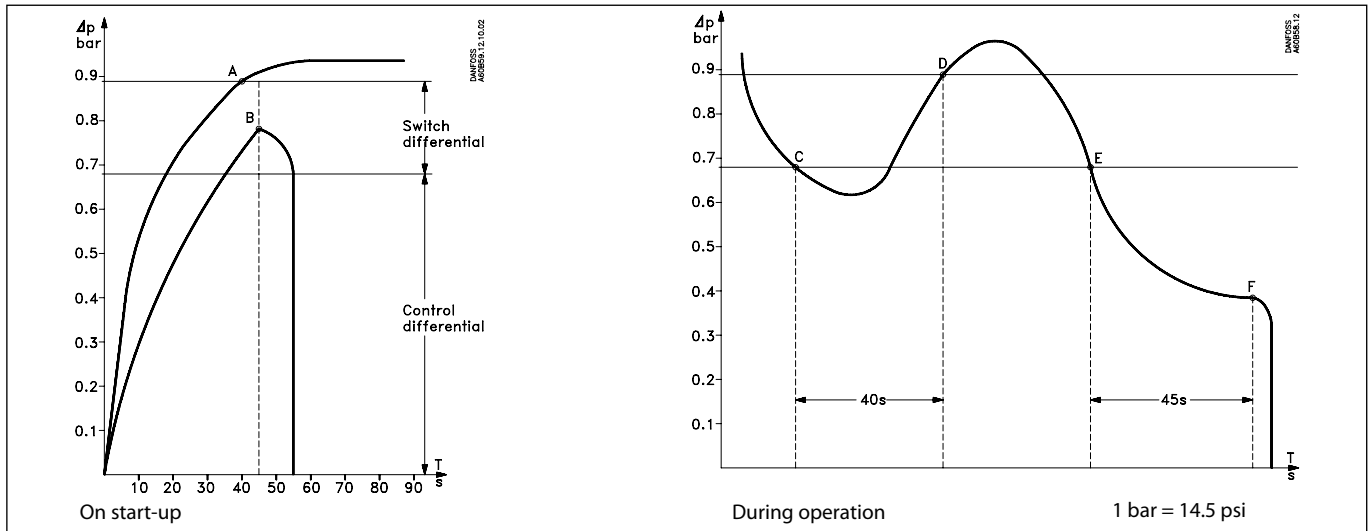

**Pos. A: Normal start-up**  
 The lubricating oil pressure is built up during start to the set/fixed differential plus the contact differential, before the timer cuts out (in this example, after 45 seconds). At point A contacts T<sub>1</sub>-T<sub>2</sub> open and timer (e) is stopped, i.e. normal lubricating oil conditions for the compressor have been established.

**Pos. B:** The lubricating oil pressure does not reach the set/fixed differential plus the contact differential before the timer period elapses. At point B the timer cuts out operational circuit L-M and the compressor stops. If a signal source is connected to terminal S, it will be activated. Restart can only be performed after about 2 minutes by activation of the reset button, provided the cause of the fault has been determined.

**Pos. C:** The lubricating oil pressure falls during operation to a value lower than the set/fixed differential. At point C, safety circuit T<sub>1</sub>-T<sub>2</sub> cuts in and the timer is activated.

**Pos. D:** The lubricating oil pressure reaches the set/fixed differential plus the contact differential before the timer period elapses. At point D, safety circuit T<sub>1</sub>-T<sub>2</sub> cuts out and the

timer is stopped, i.e. normal lubricating the timer is stopped, i.e. normal lubricating oil conditions for the compressor have been established.

**Pos. E:** The lubricating oil pressure falls to a value lower than the set/fixed differential during operation. At point E, safety circuit T<sub>1</sub>-T<sub>2</sub> cuts in and the timer is activated.

**Pos. F:** The lubricating oil pressure remains lower than the set/fixed differential. At point F the timer cuts out operational circuit L-M and the compressor stops. If a signal source is connected to terminal S, it will be activated. Restart can only be performed after about 2 minutes by activation of the reset button, provided the cause of the fault has been determined.

**After start-up**  
 It is important that a function check should be made to ensure that the differential pressure control is operating as it should. This check can be made by pressing the test device (inside the unit on the left hand side). When the test device is pressed down and held in this position the compressor motor should stop after the release time determined by the time relay has elapsed.

Danfoss can accept no responsibility for possible errors in catalogues, brochures and other printed material. Danfoss reserves the right to alter its products without notice. This also applies to products already on order provided that such alterations can be made without consequential changes being necessary in specifications already agreed. All trademarks in this material are property of the respective companies. Danfoss and the Danfoss logotype are trademarks of Danfoss A/S. All rights reserved.